

# PLAYER MAP



Plan 3D

Relationship Plan: Who, What, How

Value Plan: Issues, Impact, Ideas

Positioning Plan: Push, Piece, Plus

Power Meter

High ●

Medium ●

Low ●

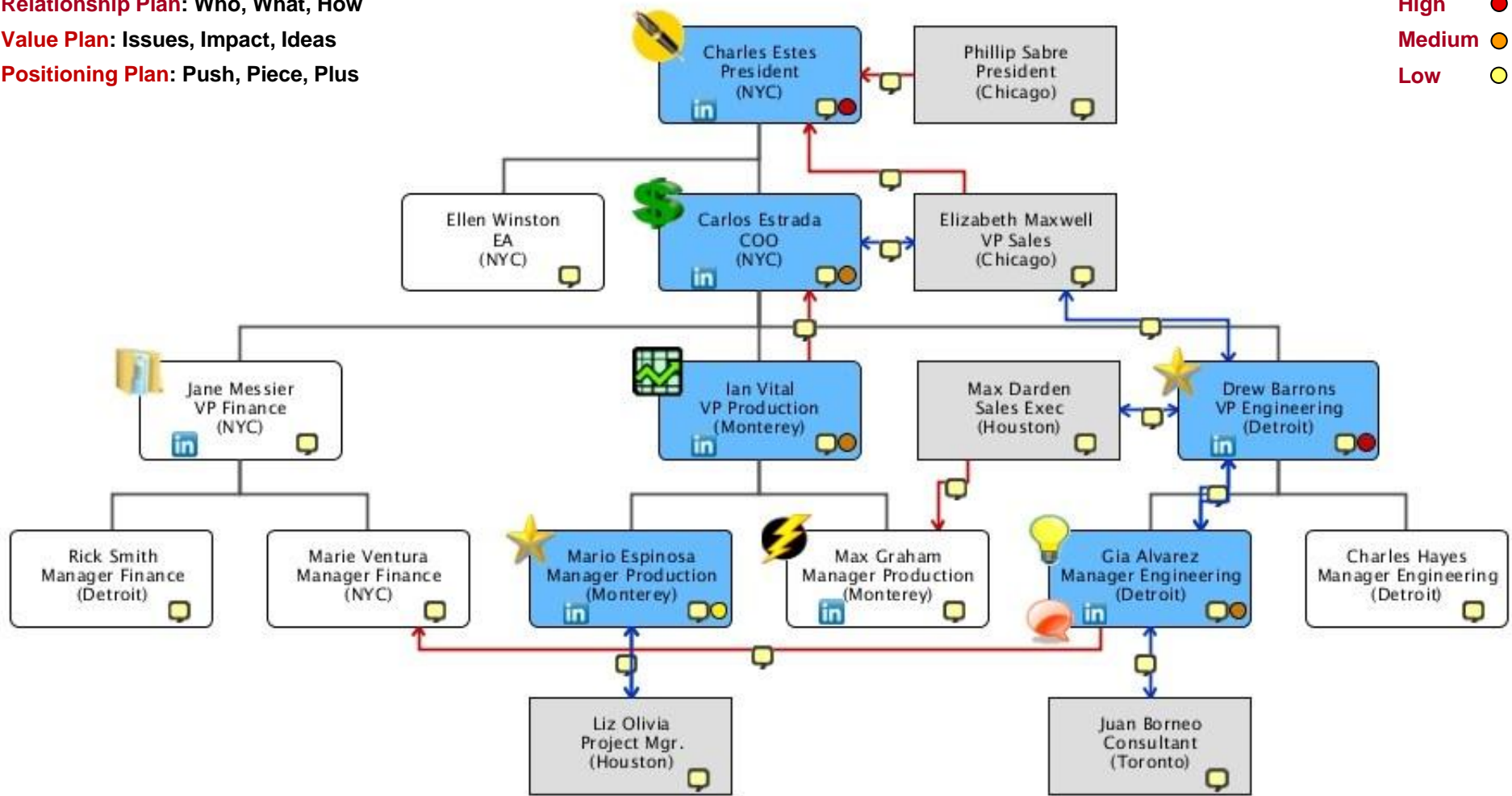

Player	Champion	Source	Solution	Business	Pen Power	Funds	Contract	Competitor	Existing Bridge	Required Bridge	Our Team	LinkedIn

Why look at your clients like this?

Charles Estes, President, NYC  
Carlos Estrada, COO, NYC  
Jane Messier, VP Finance, NYC  
Ian Vital, VP Production, Monterey  
Drew Barrons, VP Engineering, Detroit

Or even this?

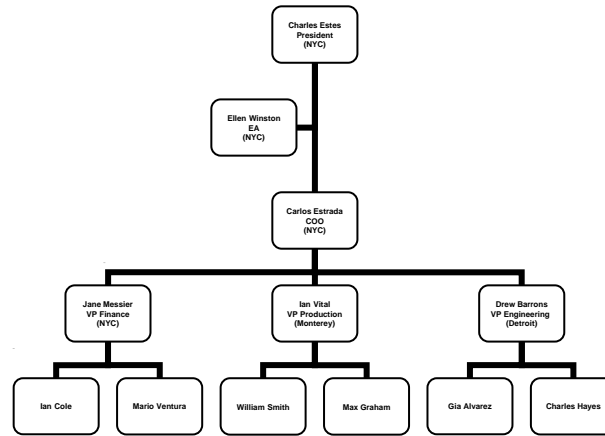

See It.

When you can see them like this!

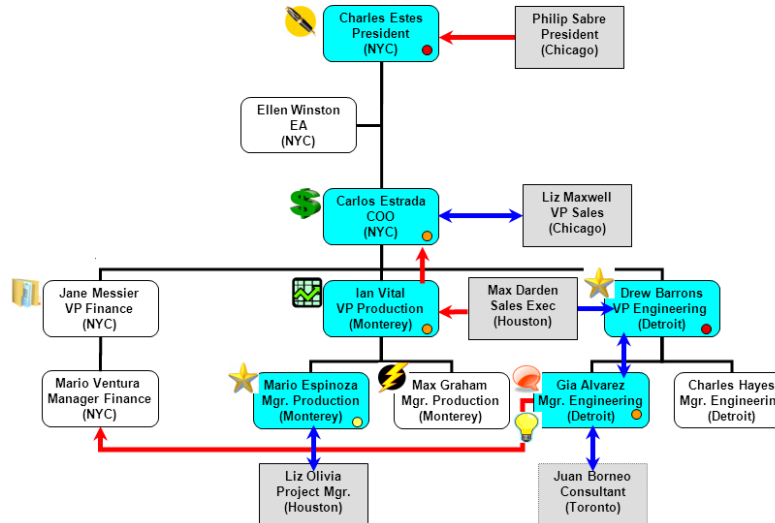

Simply click & type the menu-driven information for your client and company, and our PLAYER MAP X-Ray app will generate in real-time your custom PLAYER MAP. Fast & easy to use, PLAYER MAP X-Ray works with Salesforce.com and LinkedIn®

PMX ninetyfive

Logged in as scott | [Home](#) | [Admin](#) | [My Account](#) | [Help](#) | [Logout](#)

Add Person

Name Player Map

Legend AutoSave Save Save & Return Return

**Add Person**

Person:  in Organization  on Our Team

Name:

Reports to:

Title:

Location:

Player:

Power:  None  Low  Medium  High

Roles:  Business  Competitor  Funds  Solution  
 Champion  Contract  Pen Power  Source

Note:

LinkedIn:

Bridges:

to:

Note:

Easy.  
Fast.  
Online.  
Anytime.

Create It.

Build multiple PLAYER MAPs, store them confidentially in your private account on our SSL secure server – once your PLAYER MAP is built...store, print, update and access anytime & anyplace, helping you manage your must-win sales at your pace!



# Win It.

Success demands you find the right players and deliver the value they want – to maximize your win rate when you only get one shot to win...PLAYER MAP

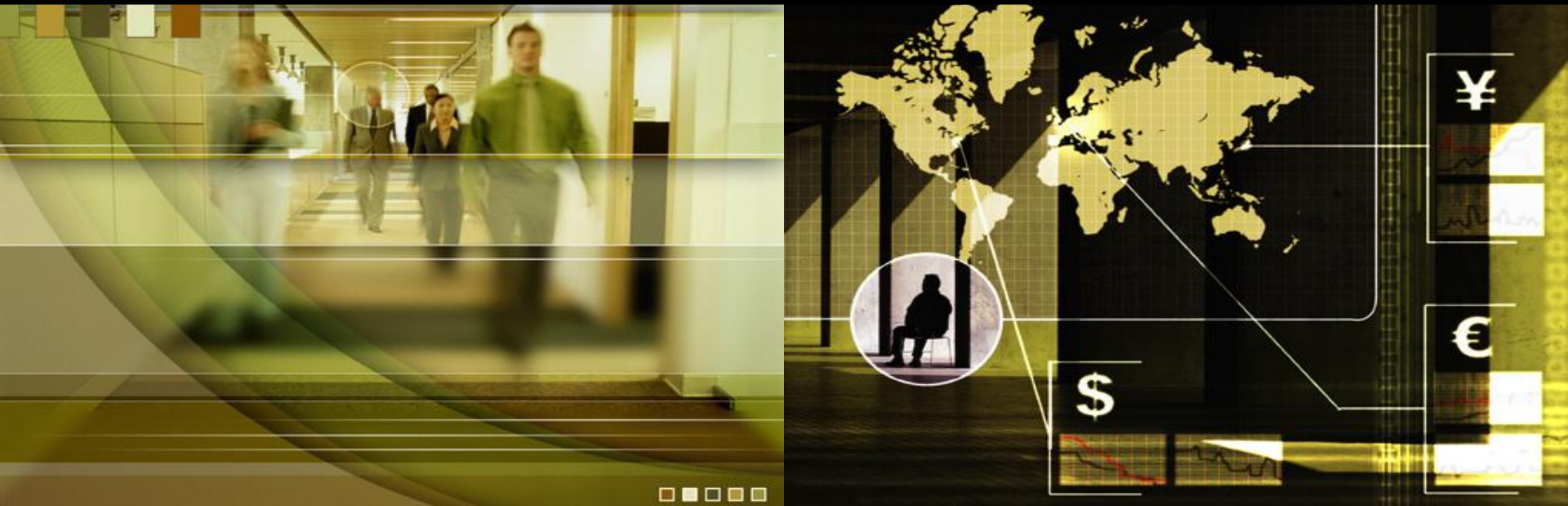

The PLAYER MAP lets you instantly see the people making the decisions and the bridges you need to cross to get to them – an x-ray of precisely how to win

**PLAYER**  **MAP**  
Visual Sales Plan